

# RoboSkyTrack

## AERIAL RACK TRANSPORT

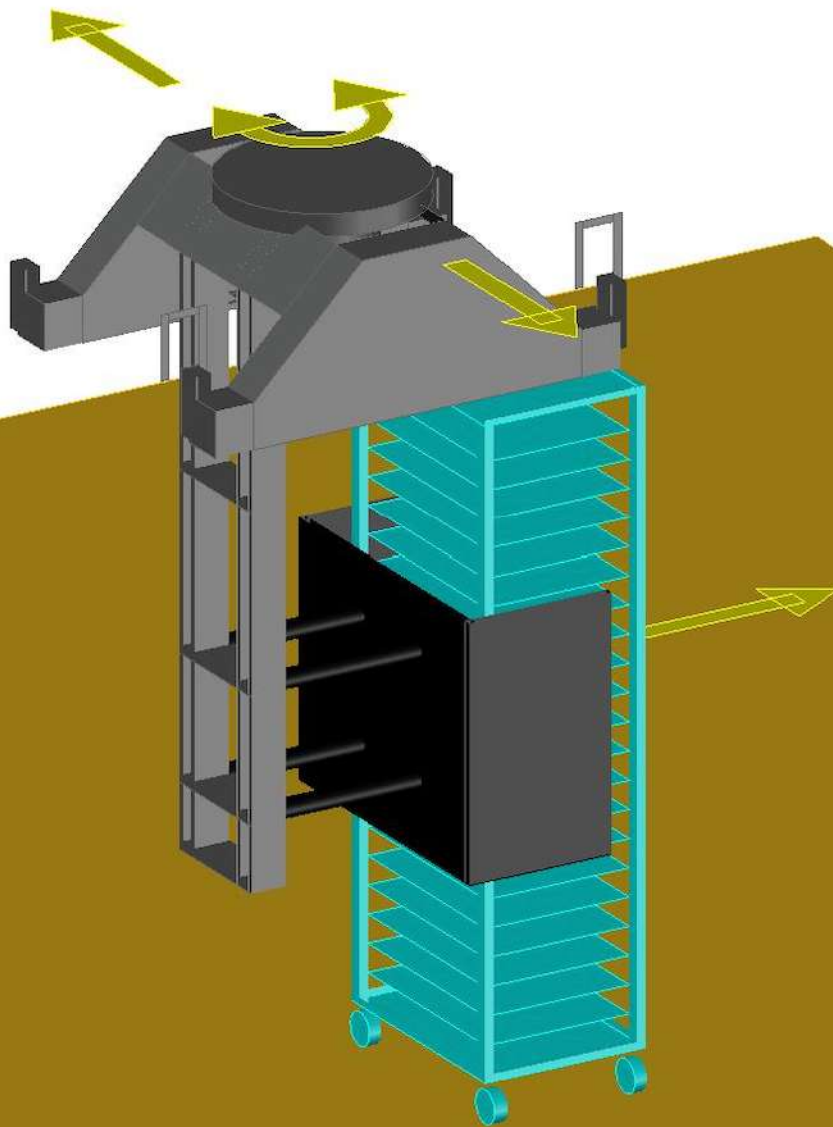

## RoboSkyTrack:

ROBOSKYTRACK® is an automated overhead system for rack transport via an aerial linear track with optional lateral and rotational movements.

Self-powered mounted gantry system allows for a clear 8ft passage underneath. Seamless integration between 2 RoboTrack lanes, linking various areas like make-up + to fermentation + to baking + to cooling and freezing.

Customized sanitary trolleys manufactured from precision-cut stainless steel plate, including large diameter polyamide wheels equipped with anti-friction ball bearings allow for smooth transport of racks.

The system can be upgraded to interface directly with rack ovens, opening and closing doors while removing and pushing in racks.

Axial actuators are suitable for use in food zones.

# RoboSkyTrack

## AERIAL RACK TRANSPORT

### SPECIFICATIONS:

- Safety sensors include 360-degree motion-activated scanning
- Visual and audible annunciation signals provide system status
- Allows for movement of racks full of product
- Performs lateral movements, insert and deposit racks
- Flexible programming, including variable speed
- Stainless steel and anodized aluminum construction
- Continuous recording of cycling performance with self-diagnostics
- PLC control choices: AB or Omron or Siemens.
- Color HMI Touchscreen, multilingual menus
- **ELECTRICAL SPECIFICATIONS:** 208-240 Volts / 50-60 Hz / 3-Phase

### BENEFITS:

- Eliminate Labor
- Reduce Workmans' comp costs
- Prevent employee litigation expenses
- Increase production. Higher run rates
- Compact. Space-saving designs
- Flexible. Expandable capabilities
- Open Frame. Easy to clean & maintain
- Fast Payback (ROI) of less than 18 month

### MODELS:

UNLIMITED MODELS ADAPTED TO THE NEEDS OF EACH CLIENT

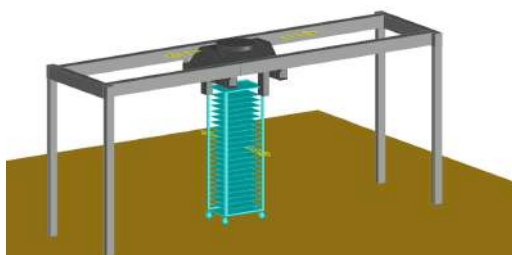

Inline

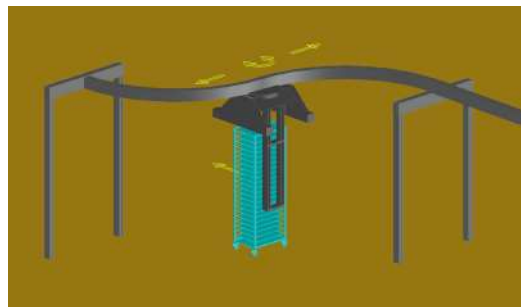

Serpentine

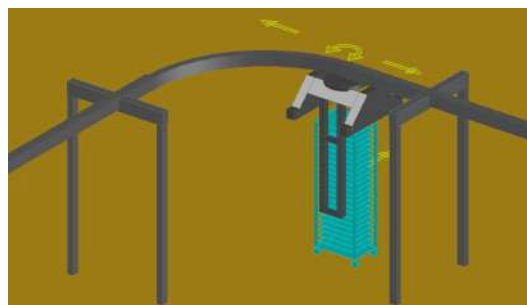

Curved

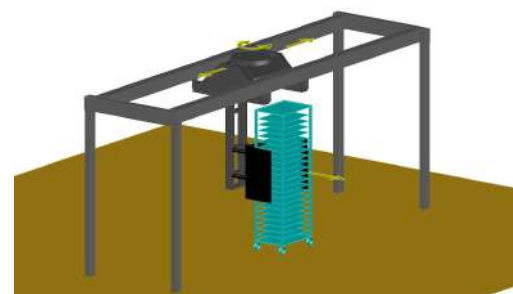

Lateral + Rotation